

Application note

Quality control and inspection of permanent magnet performance

IFM06 integrating Fluxmeter, 150mm Helmholtz coil (HH-150)

Objectives

The Hirst standard Helmholtz (HH-XXX range) coils are an easy addition to the Hirst IFM06 integrating fluxmeter for a fast, accurate and a low-cost measuring technique to monitor the quality of permanent magnets of all kinds. Sample batch testing can be used to verify specifications of the magnets prior to assembly. Many strategies exist on sample strategy from 100% testing to a random batch test. For the greatest sensitivity and resolution in the measurement of the magnet, it is sensible to pick the smallest coil size for the sample to be tested (see the Standard Helmholtz coils brochure for details on how to pick the appropriate coil size).



Above is a HH-150 mounted (left) on its side and vertically (right) with the standard magnet sample table (included). Note the IFM06 fluxmeter is sold separately.

Instrumentation

- Hirst IFM06 integrating fluxmeter
- Hirst HH-150mm Helmholtz coil pair with integral sample table – the standard range of Helmholtz coils available are 75mm,150mm, 300mm and 500mm.

Key benefits

- Easy to use and low-cost measurement technique
- Precise and accurate within 1% if the correct coil is chosen for a given magnet sample.
- Meets international testing standards (IEC 60404-14)
- Non-destructive method of testing magnet samples
- Measurements the magnetic flux are used as the reference criteria for cross-comparison between suppliers and customers for statistical process control (SPC) and quality control (QC) purposes.

Applications

- Production Quality Control (QC) of permanent magnets and assemblies such as magnetised sensor component, loudspeakers and high-performance permanent magnets prior to assembly in IPM, SPM or Axial flux motors.

Background

Helmholtz coils are named after the German physicist Hermann von Helmholtz. It is comprised of two identical magnetic coils positioned parallel to each other, and their centres aligned in the same x-axis. The two coils are separated by a distance equal to the radius (R). When current is passing through the two coils in the same direction, it generates a uniform magnetic field in the region of space within the coils as shown below. Helmholtz coils are normally used for scientific experiments, magnetic calibration or to cancel the Earth's background magnetic field.

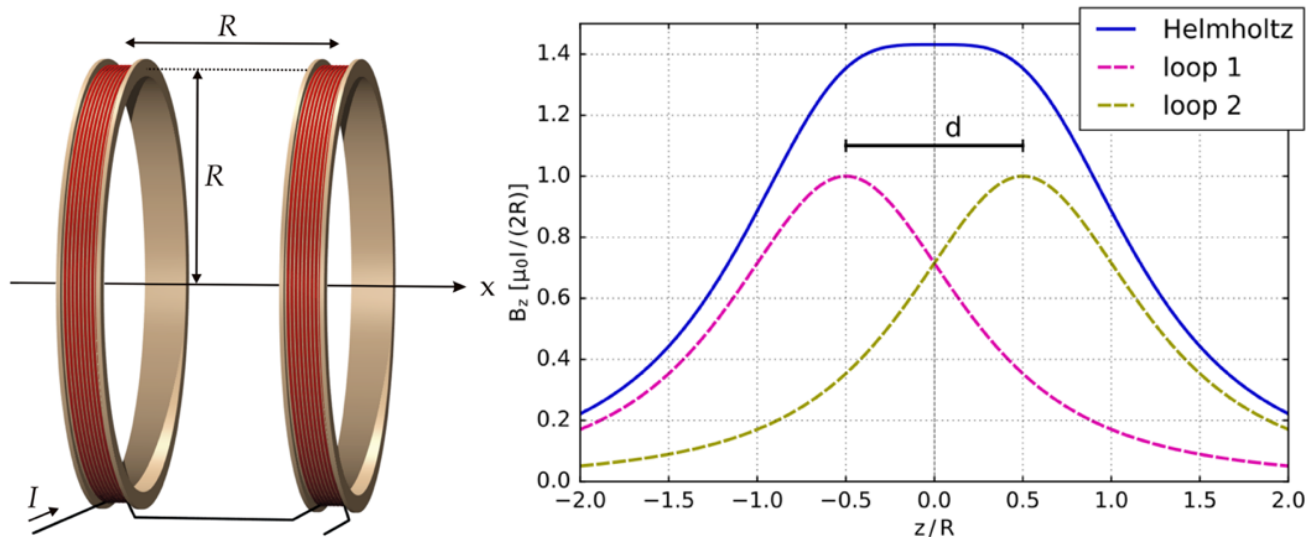

Note HH coil schematic by Ansgar Hellwig - created with Povray 3.5, Corel Draw 11 and The Gimp 2.2, CC BY-SA 3.0, <https://commons.wikimedia.org/w/index.php?curid=193184> and HH resulting field graph by <https://commons.wikimedia.org/wiki/User:Geek3>

Measurement basics

The magnetic moment of a magnet can be determined with the Helmholtz coil. First reset the IFM06 to zero, the magnet is then inserted into the coil with its magnetic axis parallel to the axis of the coil (i.e. North and South poles parallel to x-axis). The magnetic moment M is then calculated from the output magnetic flux Φ (in Vs) reading of the IFM06 multiplied by the coil constant K (from the calibration certificate supplied with each Hirst Helmholtz coil). This measurement procedure is described in the International Standard IEC 60404-14. The resistance of the coil can be neglected if it is less than 1 % of the input resistance of the fluxmeter but this is not always the case which results in gain errors which need to be corrected. The IFM06 set up allows the resistance of the attached coil to be entered allowing for automatic correction of any gain errors for the greatest measurement accuracy possible. The standard Hirst Helmholtz coils each come with an individual serial number and a coil constant and coil resistance calibration certificate.

Before measuring with Helmholtz coil, it is necessary to ensure that in a radius of 50 cm no external magnetic influences are present (steel, iron etc) that could impact the accuracy of the measurement.

For a permanent magnet sample of volume V (cm³), intrinsic flux density B_{di} in Tesla can be calculated by dividing the magnetic moment M by the magnet sample volume V. These may be supplied on the magnet's datasheet, but a more detailed method is described below to link these parameters to other magnet datasheet parameters.

The size of the sample determines the right size of Helmholtz coil. For the greatest sensitivity and resolution in the measurement of the magnet, it is sensible to pick the smallest coil size for the sample to be tested (see the Standard Helmholtz coils brochure for details on how to pick the appropriate coil size).

Method

Connect the IFM06 to the Helmholtz coil using 4mm banana plug leads ensuring the polarity is respected.

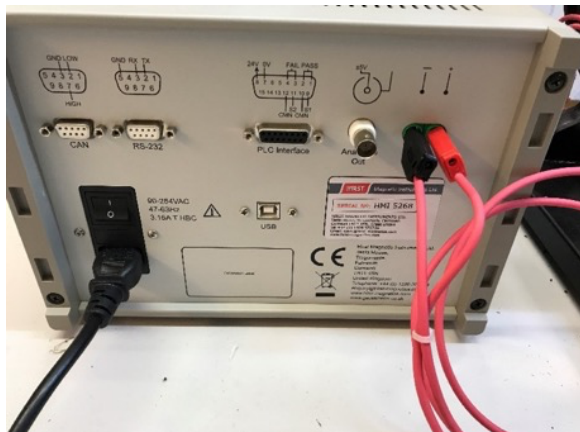

Switch the IFM06 unit on, press the yellow button (auto drift correction is engaged) on the front of the IFM06 and allow to warm up for at least 5 minutes.

Ensure the calibration constants are correct for the Helmholtz coil. In the Helmholtz coil used the coil constant (k) of 0.0011197m given on the calibration certificate. This is sometimes given in meters or cm, it is generally more useful to enter this as a value $\times 1,000,000$ larger to account for the fact magnet data is normalised to cubic centimetres, so in this case the value entered into the IFM06 for k would be 1111.97 and there is an approximation of this to 3 decimal places displayed in top left corner of the screen as 1.120×10^3 (displayed as 1.120e+03).

In addition, the resistance (R) of the Helmholtz coil is entered as 8.000 Ohms (displayed as 8.000e+00). This value is also from the calibration certificate supplied with each coil.

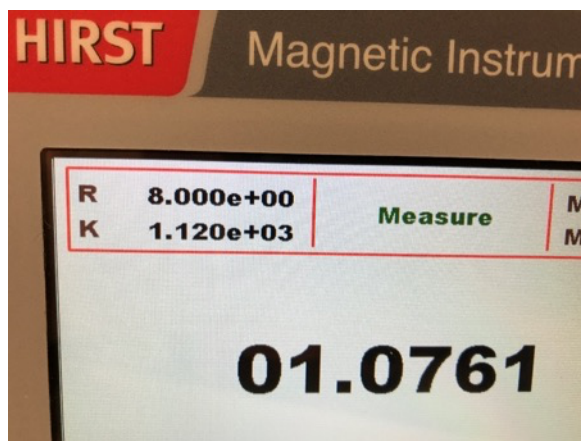

Below is a picture of the magnet under test, it is a 10mm diameter \times 10mm high or 0.785cm^3 volume with the 2 poles on the flats. The magnet in question is a calibration sample of N42SH (grade N42 mean the a neodymium magnet (NdFeB) has a median energy product of 42 MGOe this refers to the magnetic energy that the material can be stored, SH refers to a suggested max temperature of operation of 150 °C). The specification is given below for this magnet. Specifically, the testing is to determine if the flux is in spec of the requirement – in this case a min of 1280 mT or 1.28 T.



Characteristic		Units	min.	nominal	max.
Magnetic Properties	B_r , Residual Induction	Gauss	12,800	13,100	13,400
		mT	1280	1310	1340
	H_{cB} , Coercivity	Oersteds	12,000	12,400	12,800
		kA/m	955	987	1019
H_{cJ} , Intrinsic Coercivity	Oersteds	20,000			
	kA/m	1,592			
BH_{max} , Maximum Energy Product	MGOe	39	42	44	
	kJ/m^3	310	330	350	

Place the magnet on the sample table so the magnetisation axis points through the coil circles, along the x-axis of the coils as described previously. The flux Range 1 is close to 100% of full scale with this sample so Range 2 on the IFM06 fluxmeter has been selected to ensure any variation in performance is within the full scale.

This test set up has a simple sample table fitted as a range of samples are being tested (supplied with the coil). If ultimate accuracy is required a custom sample holder can be used to give a precise sample location.

1. With the sample in place in the Helmholtz coils press reset (red button) on the flux meter.
2. Then press measure on the IFM06 (green button)
3. Remove the sample move it far away from the coil. Even this small 10mm x 10mm magnet still has some effect at 1m distance.
4. Note the reading 0.9958T, this value is Tesla per cubic centimetre (cm³) so needs adjusting for the magnet volume of 0.785cm³.

Another variation on this method is to insert the magnet, press reset, press measure button, then rotate the magnet by 180 degrees and note the resulting reading. The value needs to be divided by 2 prior to the next stage. This method can be preferable but takes slightly longer.

Performing this calculation $0.9958\text{T}/0.785\text{cm}^3 = 1.269\text{T}$

Also note that this is the intrinsic flux density value B_{di} , not the closed-circuit flux density B_r value shown on the data sheet.

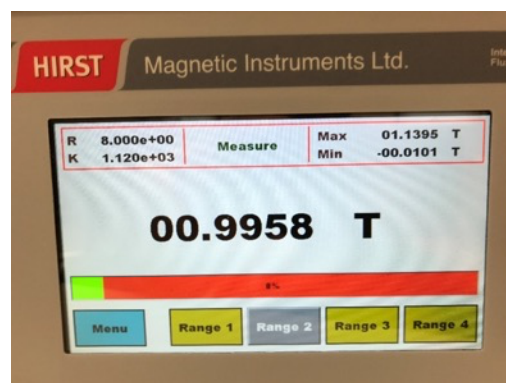

Thus, once the intrinsic flux density is obtained a simple calculation can be performed to get the actual closed-circuit flux density or remanence (B_r) of the magnet.

To do this we need some properties of the magnet being measured. These can be obtained from datasheets or extracted from 2nd quadrant of the magnetic hysteresis plot of the magnet material. If we consider a typical 2nd quadrant of a NdFeB magnet the relationship between the various parameters can be seen graphically these are obtained via either via direct measurement or more likely from the magnet material datasheet: -

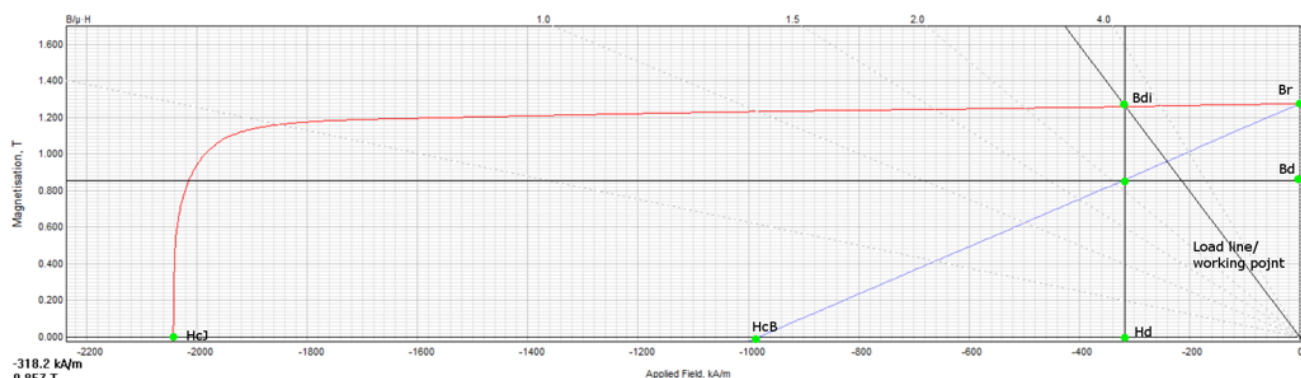

Above typical magnet 2nd quadrant obtained from the magnet datasheet.

From this datasheet the actual B_r value is 1.274T but the value obtained from a Helmholtz coil (B_{di}) is only 1.257 T due to the magnet being “open circuit” and the actual magnetic moment will be on the load line shown in black. The exact change in value will depend on the shape of the magnet. The flatter the magnet the more the load line will rotate to the left, the longer and thinner the magnet the more vertical the load line becomes and the closer the to the actual B_r value. To determine the actual B_r and other parameters it is necessary to lookup or calculate the Permeance Coefficient (P_c), and the recoil permeability R_p . For more details see the IFM06 manual.

$$B_r = \frac{B_{di} \cdot (R_p + P_c)}{P_c + 1}$$

The permeance coefficient - P_c is a function of magnet shape and which we can calculate from the self-demagnetisation factor, N .

$$P_c = 1 - \frac{1}{N}$$

In this case N was determined to be 0.315 (from Demagnetising Factors for Cylinders, Du-Xing Chen, James A. Brug, Member, IEEE, and Ronald B. Goldfarb, Senior Member, IEEE, IEEE TRANSACTIONS ON MAGNETICS, VOL. 21, NO. 4, JULY 1991). Thus, P_c is calculated to be 2.17.

The recoil permeability (R_p) for NdFeB magnets can be gained from the datasheet or published data and is 1.05. So, performing this calculation $B_r = 1.269 * (1.05+2.17) / (2.17+1)$ and gives the closed loop flux density B_r for this test sample as 1.289 T.

This is the method described in IEC 60404-14 and can of course be performed in excel or similar spreadsheet or graphing software to allow raw results to be calculated and further analysed for SPC and QC analysis.

Conclusions

When compared to the data sheet, this magnet is within specification, but close to the bottom performance level acceptable according to the datasheet. The test took less than 30seconds making it the perfect QC measurement for batch testing or random testing.

The same sample was measured on a Gen 7 Hirst Pulse field Magnetometer (PFM) model 14 (a significantly more accurate measurement method) and B_r was found to be 1.285 T indicating that the Helmholtz coil and fluxmeter method is a sufficiently accurate measurement. Whilst a PFM provides a full magnet parameter set and with a greater accuracy measurement it is slower and the capital cost of the IFM06 and Helmholtz coil set up is about 1/10th the cost of a PFM making this a perfect QC measurement technique and meets international testing standard IEC 60404-14.

This is an easy to use and low-cost measurement technique which is precise and accurate within 1% if the correct coil is chosen for a given magnet sample. It also meets international testing standards (IEC 60404-14) and provides a Non-destructive method of testing magnet samples. The measurements the magnetic flux can be used as the reference criteria for cross-comparison between suppliers and customers for statistical process control (SPC) and quality control (QC) purposes.

Note a range of Helmholtz coils are available from 75mm to 500mm

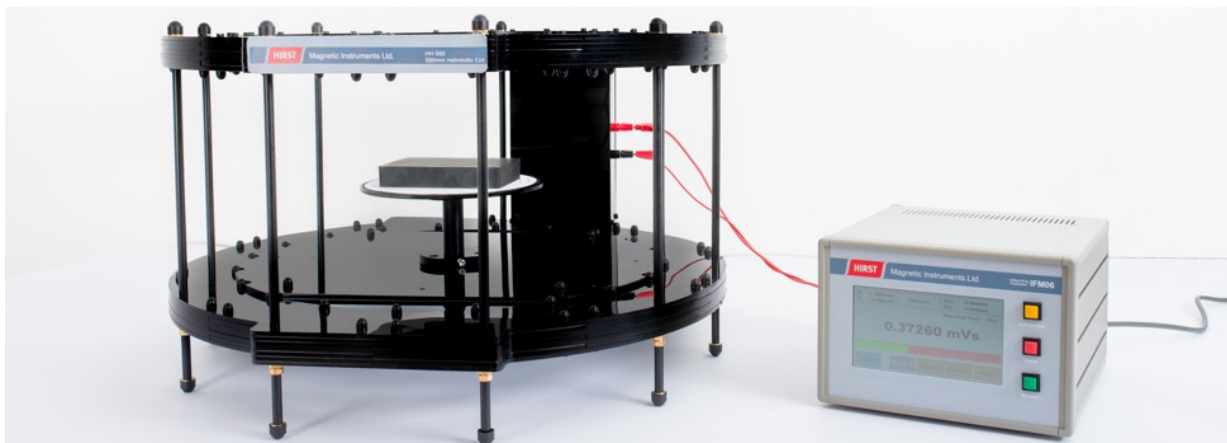
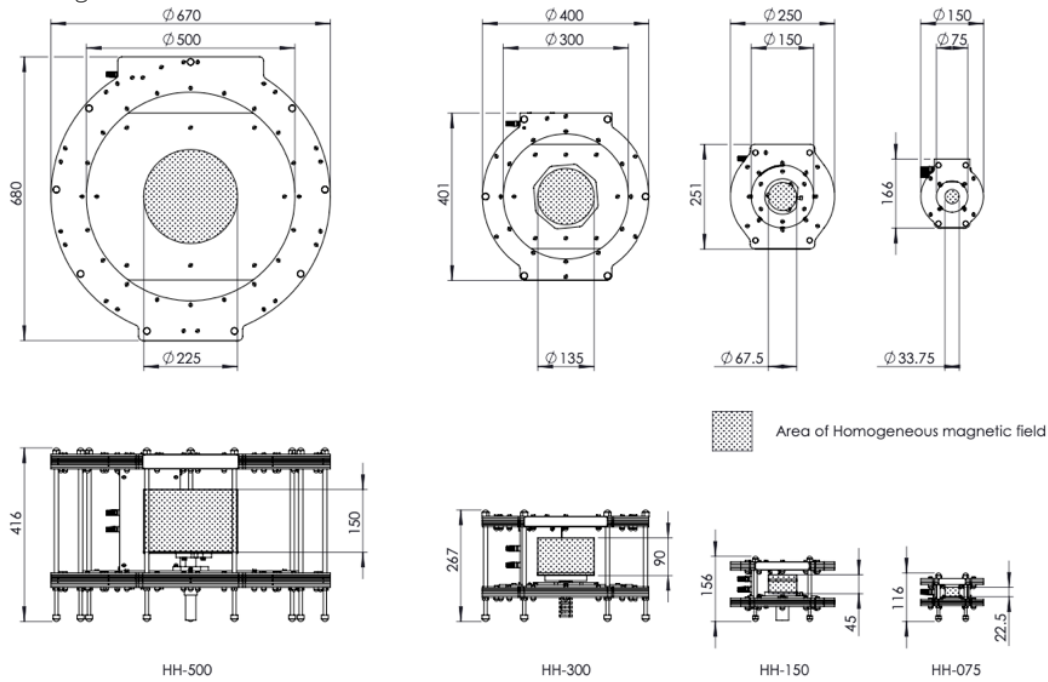

Above is the HH-500



Hirst Magnetic Instruments has been active in providing solutions for 60 years in magnetics and magnetic measurement. Hirst manufacture precision hand-held gaussmeters, Fluxmeters, de-magnetisers, bench top & workstation industrial magnetisers, industrial production-line magnetisers, pulse field magnetometers (PFMs) for developing and characterising magnetic materials.

Hirst Magnetic Instruments Ltd reserves the right to make changes to any specifications or performance implied in this product brochure without notice – please refer to www.hirst-magnetics.com for the latest version.

IFM06 and HH-xxx application note v1.5 7.10.22